

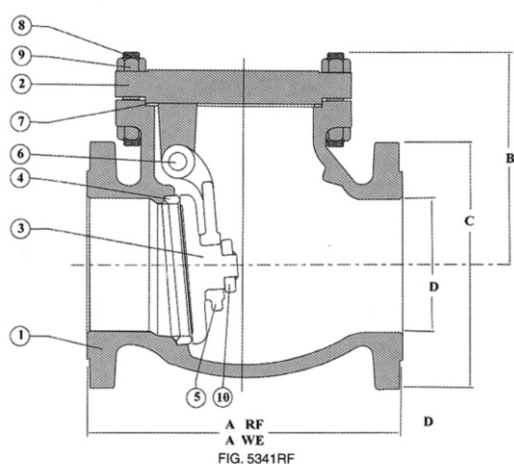

Figura No.	Tipo de Extremo
5341RF	Bridados cara realzada
5341RTJ	Bridados junta tipo anillo
5341WE	Soldables a tope



## VÁLVULAS DE RETENCIÓN CLASE 150

### LISTA DE MATERIALES

No.	Descripción	Material Estándar
1	Cuerpo	ASTM A 216 GR WCB
2	Tapa	ASTM A 216 GR WCB
3	Disco	ASTM S 216 GR WCB + 13% Cr
4	Asiento	ASTM 515 GR 70 + ST 6
5	Horquilla	ASTM A 216 GR WCB
6	Flecha	ASTM 276 Tipo 410
7	Junta	Grafito/Inoxidable 316
8	Espárrago	ASTM 193 GR B7
9	Tuerca Espárrago	ASTM A 194 GR 2H
10	Tuerca Retén	Acero Aleado
11	Tapón Cuerpo**	Acero Aleado
12	Placa de Identificación	Acero Inoxidable

\*No indicado  
\*\*14" y mayores

### DIMENSIONES Y PESOS

D Diámetro Nominal	mm pulg	51 2	64 2 1/2	76 3	102 4	157 6	203 8	254 10	305 12	356 14	406 16	457 18	508 20	610 24
A (RF) y (WE)	mm pulgadas	203 8	216 8 1/2	241 9 1/2	292 11 1/2	356 14	495 19 1/2	622 24 1/2	699 27 1/2	787 31	864 34	978 38 1/2	978 38 1/2	1295 51
B	mm pulgadas	134 5 3/2	164 6 5/8	162 6 3/8	205 8 1/16	238 9 3/8	290 11 7/16	349 13 3/4	381 15	457 18	502 19 3/4	573 23 1/16	606 23 3/8	702 27 5/8
C	mm pulgadas	152 6	178 7	191 7 1/2	229 9	279 11	343 13 1/2	406 16	483 19	533 21	597 23 5/2	635 25	699 27 1/2	813 32
PESO 5341RF	kg lb	15 33	23 51	26 57	36 79	70 154	152 335	242 533	350 771	527 1161	650 1432	950 2093	1150 2533	1596 3515
PESO 5341WE	kg lb	13 29	17 37	17 37	30 66	55 121	132 291	210 463	305 672	458 1009	565 1244	825 1817	1000 2203	1388 3057

