

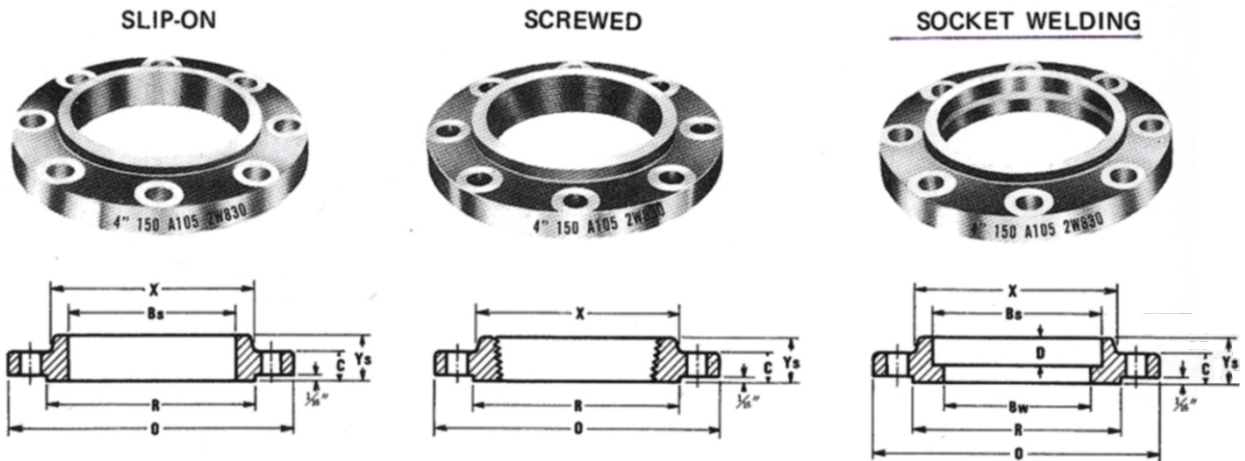

150 LB ANSI B16.5 FORGED FLANGES



| Nominal Pipe Size | Common Dimensions | | | | Dia Of hub at bevel A | Length Thru hub | | | Center-to-End | | |
|-------------------|--------------------------|--------------------|-----------------------|-----------------------|-----------------------|----------------------------|-----------------|--------------|--------------------|-------------------------|--------------|
| | Outside Dia. of flange O | Thick. of flange C | Dia. of Hub at Base X | Dia. of Raised Face R | | Slip-on screwed, socket Ys | Welding Neck Yw | Lap Joint Yl | Slip-on, Socket Bs | Welding Neck, Socket Bw | Lap Joint Bl |
| 1/2 | 3 1/2 | 7/16 | 1 3/16 | 1 3/8 | .84 | 5/8 | 1 7/8 | 5/8 | .88 | .62 | .90 |
| 3/4 | 3 7/8 | 1/2 | 1 1/2 | 1 11/16 | 1.05 | 5/8 | 2 1/16 | 5/8 | 1.09 | .82 | 1.11 |
| 1 | 4 1/4 | 9/16 | 1 15/16 | 2 | 1.32 | 11/16 | 2 3/16 | 11/16 | 1.36 | 1.05 | 1.38 |
| 1 1/4 | 4 5/8 | 5/8 | 2 5/8 | 2 1/2 | 1.66 | 13/16 | 2 1/4 | 13/16 | 1.70 | 1.38 | 1.72 |
| 1 1/2 | 5 | 11/16 | 2 9/16 | 2 7/8 | 1.90 | 7/8 | 2 7/16 | 7/8 | 1.95 | 1.61 | 1.97 |
| 2 | 6 | 3/4 | 3 1/16 | 3 5/8 | 2.38 | 1 | 2 1/2 | 1 | 2.44 | 2.07 | 2.46 |
| 2 1/2 | 7 | 7/8 | 3 9/16 | 4 1/8 | 2.88 | 1 1/8 | 2 3/4 | 1 1/8 | 2.94 | 2.47 | 2.97 |
| 3 | 7 1/2 | 15/16 | 4 1/4 | 5 | 3.50 | 1 3/16 | 2 3/4 | 1 3/16 | 3.57 | 3.07 | 3.60 |
| 3 1/2 | 8 1/2 | 15/16 | 4 13/16 | 5 1/2 | 4.00 | 1 1/4 | 2 13/16 | 1 1/4 | 4.07 | 3.55 | 4.10 |
| 4 | 9 | 15/16 | 5 5/16 | 6 3/16 | 4.50 | 1 5/16 | 3 | 1 5/16 | 4.57 | 4.03 | 4.60 |
| 5 | 10 | 15/16 | 6 7/16 | 7 5/16 | 5.56 | 1 7/16 | 3 1/2 | 1 7/16 | 5.66 | 5.05 | 5.69 |
| 6 | 11 | 1 | 7 7/16 | 8 1/2 | 6.63 | 1 9/16 | 3 1/2 | 1 9/16 | 6.72 | 6.07 | 6.75 |
| 8 | 13 1/2 | 1 1/8 | 9 11/16 | 10 5/8 | 8.63 | 1 3/4 | 4 | 1 3/4 | 8.72 | 7.98 | 8.75 |
| 10 | 16 | 1 3/16 | 12 | 12 3/4 | 10.75 | 1 15/16 | 4 | 1 15/16 | 10.88 | 10.02 | 10.92 |
| 12 | 19 | 1 1/4 | 14 3/8 | 15 | 12.75 | 2 3/16 | 4 1/2 | 1 3/16 | 12.88 | 12.00 | 12.92 |
| 14 | 21 | 1 3/8 | 15 3/4 | 16 1/4 | 14.00 | 2 1/4 | 5 | 3 1/8 | 14.14 | 13.25 | 14.18 |
| 16 | 23 1/2 | 1 7/16 | 18 | 18 1/2 | 16.00 | 2 1/2 | 5 | 3 3/16 | 16.16 | 15.25 | 6.19 |
| 18 | 25 | 1 1/16 | 19 7/8 | 21 | 18.00 | 2 11/16 | 5 1/2 | 3 3/16 | 18.18 | 17.25 | 18.20 |
| 20 | 27 1/2 | 1 11/16 | 22 | 23 | 20.00 | 2 7/8 | 5 11/16 | 4 1/16 | 20.20 | 19.25 | 20.25 |
| 24 | 32 | 1 7/8 | 26 1/8 | 27 1/4 | 24.00 | 3 1/4 | 6 | 4 3/8 | 24.25 | 23.25 | 24.25 |

* Material: To be specified when ordering. See Page

